

ASD 535

Aspirating Smoke Detector

Application guidelines for refrigerated warehouses

Beginning with SW version 01.02.01



Imprint



Notice

This document, T 131 390, is valid only for the product described in technical description T 131 192 in section 1. This document constitutes the application guidelines for the use of the Aspirating Smoke Detector ASD 535 in refrigerated warehouses. Technical description T 131 192 is a component of the application guidelines.

In the T 131 390 application guidelines, only the points that are necessary for implementing and operating the ASD 535 in refrigerated warehouses are included. The general specifications of the ASD 535 aspirating smoke detector are found in technical description T 131 192.

This documentation is subject to change or withdrawal without prior notice. The validity of the statements made in the documentation applies until the statements are revised by a new edition of the documentation (T number with new index). Users of this documentation are responsible for staying up-to-date about the current status of the documentation via the editor/publisher. We accept no responsibility for claims against any possible incorrect statements in this documentation which were unknown to the publisher at the time of publication. Handwritten changes and additions have no validity. This documentation is protected by copyright.

Foreign language documentation as listed in this document is always released or changed at the same time as the German edition. If there are inconsistencies between the foreign language documentation and the German documentation, the German documentation is binding.

Some words are printed highlighted in **blue**. These are terms and designations which are the same in all languages and are not translated.

Users are encouraged to contact the editor/publisher if there are statements which are unintelligible, misleading, incorrect, or if there are errors.

© Securiton AG, Alpenstrasse 20, 3052 Zollikofen, Switzerland

This document, T 131 390, is available in the following languages:

German	T 131 390 de
English	T 131 390 en
Italian	T 131 390 it

Current edition: First edition 21.04.2009 Po / ksa

Other documents

Technical Description ASD 535		T 131 192	de / en / it
Application guidelines for detection systems (in preparation)		T 131 391	de
Data sheet ASD 535		T 131 193	de / en / it
Material for the sampling pipe		T 131 194	Multilingual (EDI)
Commissioning protocol		T 131 199	Multilingual (EDFI)
Data sheets	SLM 35	T 131 197	de / en / it
	RIM 35	T 131 196	de / en / it
	MCM 35	T 131 195	de / en / it
Installation instructions for aspirating fan unit		T 131 200	Multilingual (EDFI)
Description of integration for ASD 535 with SecuriPro®		T 131 218	de / en / it



Notice

Applicability for production version and software version

The following documentation is applicable only to the ASD 535 aspirating smoke detector with the following production version and software version:

Production version	SW version
From 060608	From 01.02.01

Safety information

Provided the product is deployed by trained and qualified persons in accordance with this document (T 131 390) and the T 131 192 technical description, and provided the hazard, safety and general information in these documents is observed, there is no danger to persons or property under normal conditions and when used properly.

National and state-specific laws, regulations and guidelines must be observed and adhered to in all cases.

Below are the designations, descriptions and symbols of general, danger, and safety information as found in this document.



Danger

If the "Danger" notice is not properly observed, the product and any other system parts may present a hazard for persons and property, or the product and other system parts may be damaged to the extent that malfunctioning results in danger to persons and property.

- Description of which dangers can occur
- Measures and preventative actions
- How dangers can be averted
- Other safety-relevant information



Warning

The product may be damaged if the warning information is not heeded.

- Description of which damage can occur
- Measures and preventative actions
- How dangers can be averted
- Other safety-relevant information



Notice

The product may malfunction if this notice is not observed.

- Description of the notice and which malfunctions can be expected
- Measures and preventative actions
- Other safety-relevant information



Environmental protection / recycling

Neither the product nor product components present a hazard to the environment provided they are handled properly.

- Description of parts for which there are environmental issues
- Description of how devices and their parts have to be disposed of in an environmentally-friendly way
- Description of the recycling possibilities

Document history

First edition Date 21.04.09

Table of contents

1	General information	9
1.1	Purpose	9
1.2	Uses and applications	9
1.3	Abbreviations, symbols and terms	9
2	Function	10
2.1	General operating principle	10
2.2	Functional principle of de-icing	10
2.3	Heating element power supply	10
3	Planning	11
3.1	Standards, regulations, guidelines, approvals	11
3.2	Area of application	11
3.3	Principles of monitoring refrigerated warehouses	11
3.4	Planning with the “ASD PipeFlow” calculation software	12
3.5	System limits for use in refrigerated warehouses	12
3.6	System limits for refrigerated warehouses without “ASD PipeFlow” calculation	13
3.6.1	Normative system limits for space surveillance without “ASD PipeFlow” calculation	13
3.6.2	Non-normative system limits for space surveillance without “ASD PipeFlow” calculation	13
3.6.3	System limit table for planning without “ASD PipeFlow” calculation	14
3.6.4	Non-normative system limits table for planning without “ASD PipeFlow” calculation	15
3.7	Sampling hole diameter	16
3.7.1	Sampling point with heating	17
3.8	Electrical installation	17
3.8.1	Determination of the conductor cross-section	17
3.8.2	Power calculation	19
4	Mounting and installation	20
4.1	General information	20
4.2	Material for the sampling pipe	20
4.3	Mounting the detector housing	21
4.3.1	Opening and closing the detector housing	21
4.3.2	Mounting positions of the detector housing	22
4.4	Mounting sampling pipe	22
4.4.1	Electrical connection of the silicon Litz wires	23
4.4.2	Mounting the heating elements on the sampling points	23
4.4.3	Mounting and installing the WCU 535 wiring connection unit	24
4.4.4	Electrical connection in the WCU 535 wiring connection unit	25
5	Commissioning	26
5.1	General information	26
5.2	Initial reset	26
5.3	Settings	26
5.3.1	Programming the heating actuation	27
5.4	Checking heating control	28
6	Article numbers and replacement parts	29
6.1	Detector housings and accessories	29
6.2	Sampling pipe and accessories	29
7	Technical data for use in refrigerated warehouses	30
8	List of figures	31

1 General information

1.1 Purpose

The ASD 535 Aspirating Smoke Detector performs the task of taking continuous air samples via one or two sampling pipe tube networks from a monitored area and feeding the samples to one or two smoke sensors. When using the ASD 535 in refrigerated warehouses, the sampling holes in the sampling pipe are equipped with heating elements which prevent ice from forming on the sampling holes.

It is imperative that the “[ASD Config](#)” configuration software is used for parameterising the ADS 535 in refrigerated warehouses. This defines heating element control (relays, subsequent heating time).

The response behaviour of the ASD 535 has been tested in compliance with EN 54-20, Class A, B and C. With the ASD 535, refrigerated warehouses can be monitored in accordance with response classes B and C in compliance with EN 54-20.

1.2 Uses and applications

Observance of the information and instructions contained in these application guidelines enables use of the ASD 535 aspirating smoke detector in refrigerated warehouses down to minus 30°C.



Warning

Shock refrigerated warehouses cannot be protected with the ASD 535 due to ice formation.

1.3 Abbreviations, symbols and terms

In this document (application guidelines T 131 390) the following abbreviations, symbols and terms are used in addition to those in technical description T 131 192. The abbreviations for tube material and accessories are listed in a separate document (T 131 194).

WCU 535	=	Wiring Connection Unit
CCF 25	=	Cable Connection Fitting
HEAT x.x	=	Sampling point with heating (x.x = sampling hole Ø)
Hz	=	Heating control
SLW	=	Silicon Litz Wire

2 Function

2.1 General operating principle

The fan generates underpressure in the sampling pipe tube networks, and this in turn causes new air to be continuously fed to the detector housing via the sampling pipes. In this way the smoke sensors are constantly supplied with new air samples from the monitored areas. Should the smoke concentration exceed the permissible value, the ASD 535 triggers an alarm. The alarm is indicated visually on the ASD 535 and can be transmitted via a potential-free change-over contact to a superordinate fire alarm control panel.

The operational reliability of the aspirating smoke detector depends on the functional reliability of the smoke sensors and on the constant air supply to the system. Fan failure, blockage of the sampling holes or pipe breakage must be communicated to the fire alarm control panel in the form of a fault signal. This condition is satisfied by the airflow monitoring (LS-Ü) of the ASD 535.

2.2 Functional principle of de-icing

Ice on the sampling holes is detected as pipe blockage by the airflow monitoring. Thus if the airflow decreases or if the pipe blockage threshold is undershot (negative deviation), the heating control is activated. During the LS-Ü delay time (**Fault** display on the ASD 535 flashes) the sampling holes are de-iced. As a result, the airflow increases and returns to the monitoring window, the **Fault** display disappears, and the LS-Ü delay time is reset. An adjustable subsequent heating time ensures that the airflow is in the monitoring window. If the LS-Ü delay time is not sufficient to de-ice the sampling holes, a fault is triggered after this procedure.

2.3 Heating element power supply

Control of the heating elements is realised by means of a relay (relay 3 of the AMB 35 for ASD 535-1 / -3 or relay of RIM 35 for ASD 535-2 / -4) for each sampling pipe tube network (I / II). The relay has to be programmed using the “**ASD Config**” configuration software with the “Heating control” event. Likewise, the subsequent heating time can also be defined with the “**ASD Config**” configuration software (default 2 min). The electrical wiring is routed from the WCU 535 wiring connection unit, which is directly after the detector housing in the sampling pipe. The cable screw unions on the ASD and WCU are used when routing the control line from the relay. From the WCU 535, two silicon Litz wires are installed from the WCU 535 directly through the sampling pipe to the heating elements of the sampling holes.

3 Planning

3.1 Standards, regulations, guidelines, approvals

Section 3 “Planning” provides guidelines for planning the ASD 535 aspirating smoke detector in refrigerated warehouses. These guidelines deal with the application as concerns the fulfilment of EN 54-20 and are intended to ensure technically trouble-free operation.

The ASD 535 aspirating smoke detector conforms to the requirements of European Standard EN 54-20, Class A to C. The following applies:

- EN 54-20, Class A highly sensitive
- EN 54-20, Class B sensitive
- EN 54-20, Class C normal

3.2 Area of application

Observance of the information and instructions contained in these application guidelines enables the ASD 535 aspirating smoke detector to monitor refrigerated warehouses down to minus 30°C in response classes B and C in accordance with EN 54-20.



Warning

Shock refrigerated warehouses, in which warm stored goods are frozen very rapidly, **cannot** be protected with the ASD 535 due to heavy ice formation.

3.3 Principles of monitoring refrigerated warehouses



Notice

In addition to the principles in technical description T 131 192, section 4.4.2, the following rules apply:

- The system limits listed in section 3.5 concerning maximum tube lengths and the number of sampling holes must **not** be exceeded.
- For changes of direction, **only 90° bends** may be used. **90° angles must not be used.**
- Only 20 mm tubes (25 mm outer) are permitted to be used. Metal tubes may be used only after consulting with the manufacturer.
- The sampling points are to be equipped with heating (HEET xx PVC / HEET xx ABS) specially designed for refrigerated warehouses (see also section 3.7.1).
- It is not permitted to use sampling hole clips, sampling points for ceiling ducts or sampling stubs.
- The sampling points always have to be accessible (fork lift, ladder).
- There must be a minimum distance of 2 m between the sampling points and lamps, airducts, and air outlet openings of cooling units.
- As accessory part, a maximum of the following is permitted to be installed in the sampling pipe: small FBS 25 PC filter-box as well as the REK detector box (max. 2 units).

3.4 Planning with the “ASD PipeFlow” calculation software

When setting up a system for refrigerated warehouses with ASD 535, it is not imperative that the “ASD PipeFlow” calculation software is used. If, however, “ASD PipeFlow” is used, the system limits in section 3.5 must be adhered to.



Notice

If the Falls “ASD PipeFlow” calculation software is used, please note the following:

- Observe the system limits according to section 3.5.
- The sampling hole diameters according to section 3.7 **must** be used in “ASD PipeFlow”.
- When calculating the project, **only** the “Calculate” function may be used in “ASD PipeFlow” (not “Optimize”).

3.5 System limits for use in refrigerated warehouses

The following system limits apply to the use of the ASD 535 aspirating smoke detector in refrigerated warehouses.

	Class B	Class C
Max. length of the sampling pipe tube network per smoke sensor (total)	140 m	200 m
Max. length of the ASD to the farthest sampling hole	80 m	80 m
Max. number of sampling holes per smoke sensor for I/U/T-shaped sampling pipe	10	10
Max. number of sampling holes per smoke sensor for H-shaped sampling pipe	8	8

3.6 System limits for refrigerated warehouses without “ASD PipeFlow” calculation

The system limits detailed in this section apply to planning without the “ASD PipeFlow” calculation software. The system limits are switch settings configured with pre-defined values. There are two areas with the following meaning:

- Normative system limits according to EN 54-20, Class **B** and **C**, switch settings **b11** to **C32** (without **A11** / **A12**)
- Non-normative system limits, switch settings **W09** to **W48** (without **W01** / **W08**).



Warning

It is not advisable to use monitoring of refrigerated warehouses compliant with EN 54-20, Class **A** (highly sensitive), because of false alarm triggering. Therefore, switch positions **A11** / **A12** and **W01** / **W08** are not enabled for refrigerated warehouses.

Fig. 1 below shows the possible sampling pipe tube networks with the definitions of the tube lengths. The maximum tube lengths and number of sampling holes as well as the required smoke sensor types are found in the tables in section 3.6.3 based on response class.

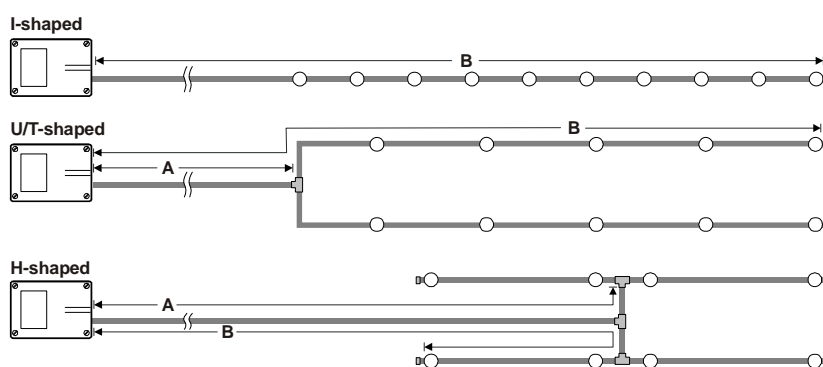

Fig. 1 Sampling pipe definitions

3.6.1 Normative system limits for space surveillance without “ASD PipeFlow” calculation

Switch settings **b11** to **C32** have configured values which are necessary for alarm response sensitivity and airflow monitoring in compliance with EN 54-20 Class B to C. The switch setting designation is deciphered as follows:

- First figure Response class (**A**), **b**, **C** (A = highly sensitive, b = sensitive, C = standard)
- Second figure System limit **1**, **2**, **3** (tube network length, number of sampling holes)
- Third figure Tube networks **1**, **2** (number of sampling pipe tube networks on the ASD 535).

Example: **b22** response class **b** / system limit **2** / **2** sampling pipe tube networks.

3.6.2 Non-normative system limits for space surveillance without “ASD PipeFlow” calculation

Switch settings **W09** to **W48** contain system limits which fulfil only the alarm response sensitivity for EN 54-20 Class B and C but not the normative limits concerning airflow monitoring. Since these are identical to system limits **b11** to **C32** concerning tube topology (tube network length, number of sampling holes), switch settings **W09** to **W48** are also included in the tables below in section 3.6.3. Additional information about switch settings **W09** to **W48** concerning the number of tube networks and airflow monitoring can be found in section 3.6.4.



Warning

Switch settings **W09** to **W48** may be used only after consulting with the manufacturer. The configured values they contain concerning airflow monitoring are not tested in accordance with EN.

Planning

3.6.3 System limit table for planning without “ASD PipeFlow” calculation

EN 54-20 compliance, Class B (sensitive)

Shape	System limit	Switch setting according to EN 54-20		Switch setting non-normative 		Smoke sensor type SSD 535	Alarm threshold (%/m)	Length from ASD to last T-piece (Fig. 1 “A”)	Max. length from ASD to the farthest sampling hole (Fig. 1 “B”)	Number of sampling holes per sampling branch	Max. total length of the sampling pipe per tube network (smoke sensor)
		1 tube	2 tubes	1 tube	2 tubes						
I	1	b11	b12	W09 – W12	W13 – W16	-3	0.09	---	50 m	1 – 7	50 m
	2	b21	b22	W17 – W20	W21 – W24	-3	0.06	---	70 m	5 – 9	70 m
U/T	1	b11	b12	W09 – W12	W13 – W16	-3	0.09	1 – 20 m	40 m	1 – 3	80 m
	2	b21	b22	W17 – W20	W21 – W24	-3	0.06	1 – 20 m	55 m	3 – 5	110 m
H	1	b11	b12	W09 – W12	W13 – W16	-3	0.09	1 – 40 m	50 m	1 – 2	90 m
	2	b21	b22	W17 – W20	W21 – W24	-3	0.06	1 – 60 m	70 m	1 – 2	110 m

EN 54-20 compliance, Class C (standard)

I	1	C11	C12	W25 – W28	W29 – W32	-1	0.8	---	40 m	1 – 5	40 m
	2	C21	C22	W33 – W36	W37 – W40	-2	0.35	---	70 m	4 – 8	70 m
	3	C31	C32	W41 – W44	W45 – W48	-2	0.13	---	80 m	7 – 10	80 m
U/T	1	C11	C12	W25 – W28	W29 – W32	-1	0.8	1 – 20 m	30 m	1 – 3	60 m
	2	C21	C22	W33 – W36	W37 – W40	-2	0.35	1 – 20 m	60 m	3 – 4	120 m
	3	C31	C32	W41 – W44	W45 – W48	-2	0.13	1 – 20 m	70 m	4 – 5	140 m
H	1	C11	C12	W25 – W28	W29 – W32	-1	0.8	1 – 30 m	40 m	1	80 m
	2	C21	C22	W33 – W36	W37 – W40	-2	0.35	1 – 50 m	60 m	1 – 2	100 m
	3	C31	C32	W41 – W44	W45 – W48	-2	0.13	1 – 70 m	80 m	1 – 2	120 m



Warning

Switch settings **W09** to **W48** may be used only after consulting with the manufacturer. The configured values they contain concerning airflow monitoring are **not** tested in accordance with EN (see section 3.6.4)



Notice

- The diameter of the sampling holes is specified in the tables in section 3.7.
- The spacing of the sampling holes is physically designed so that the resulting monitoring area meets country-specific guidelines.
- The specifications apply to one and two tube networks. Tube inputs I and II are allocated, both symmetrically and identically laid out (deviation $\pm 10\%$; also applies to the distance between sampling holes).
- The specifications are valid with and without detector box (REK, max. 2 units) and small filter-box FBS 25 PC.
- If a filter-box is used, it must always be installed within the first 2 m from the ASD 535.

3.6.4 Non-normative system limits table for planning without “ASD PipeFlow” calculation

The following table shows the parameters for switch settings *W09* to *W48* that do not conform to EN 54-20 concerning airflow monitoring. It also shows the number of tube networks for these switch settings. The tube topology specifications (tube network length, number of sampling holes) are shown in the tables in section 3.6.3.

Alarm triggering according to EN 54-20		System limit	Number of tube networks	Airflow monitoring		Switch setting
				Delay time	Deviation	
Sensitive	B	1	1	10 min	± 20%	W09
	B	1	1	60 min	± 20%	W10
	B	1	1	10 min	± 50%	W11
	B	1	1	60 min	± 50%	W12
	B	1	2	10 min	± 20%	W13
	B	1	2	60 min	± 20%	W14
	B	1	2	10 min	± 50%	W15
	B	1	2	60 min	± 50%	W16
	B	2	1	10 min	± 20%	W17
	B	2	1	60 min	± 20%	W18
	B	2	1	10 min	± 50%	W19
	B	2	1	60 min	± 50%	W20
	B	2	2	10 min	± 20%	W21
	B	2	2	60 min	± 20%	W22
	B	2	2	10 min	± 50%	W23
	B	2	2	60 min	± 50%	W24
Standard	C	1	1	10 min	± 20%	W25
	C	1	1	60 min	± 20%	W26
	C	1	1	10 min	± 50%	W27
	C	1	1	60 min	± 50%	W28
	C	1	2	10 min	± 20%	W29
	C	1	2	60 min	± 20%	W30
	C	1	2	10 min	± 50%	W31
	C	1	2	60 min	± 50%	W32
	C	2	1	10 min	± 20%	W33
	C	2	1	60 min	± 20%	W34
	C	2	1	10 min	± 50%	W35
	C	2	1	60 min	± 50%	W36
	C	2	2	10 min	± 20%	W37
	C	2	2	60 min	± 20%	W38
	C	2	2	10 min	± 50%	W39
	C	2	2	60 min	± 50%	W40
	C	3	1	10 min	± 20%	W41
	C	3	1	60 min	± 20%	W42
	C	3	1	10 min	± 50%	W43
	C	3	1	60 min	± 50%	W44
C	3	2	10 min	± 20%	W45	
C	3	2	60 min	± 20%	W46	
C	3	2	10 min	± 50%	W47	
C	3	2	60 min	± 50%	W48	



Warning

Switch settings *W09* to *W48* may be used only after consulting with the manufacturer. The configured values they contain concerning airflow monitoring are **not** tested in accordance with EN.

3.7 Sampling hole diameter

To ensure that all sampling holes take in the same amount of air, the sampling hole diameter increases as the distance from the detector housing increases.

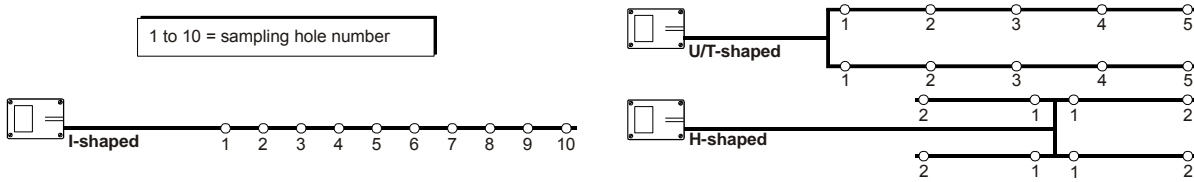

Fig. 2 Size of the sampling holes

The tables below show the respective hole diameters for the numbers in Fig. 2 as a function of the number of sampling holes per sampling branch (see section 3.7.1).

I-shaped sampling pipes										
Number of sampling holes per sampling branch	Hole diameter in mm for the sampling hole number counted from the detector housing:									
	1	2	3	4	5	6	7	8	9	10
1	5.0									
2	4.0	5.0								
3	4.0	4.0	5.0							
4	3.5	3.5	4.0	5.0						
5	3.5	3.5	3.5	4.0	5.0					
6	3.0	3.0	3.0	3.0	3.5	5.0				
7	3.0	3.0	3.0	3.0	3.0	3.5	5.0			
8	3.0	3.0	3.0	3.0	3.0	3.0	3.5	5.0		
9	3.0	3.0	3.0	3.0	3.0	3.0	3.0	3.5	5.0	
10	3.0	3.0	3.0	3.0	3.0	3.0	3.0	3.0	3.5	5.0

U/T-shaped sampling pipes					
Number of sampling holes per sampling branch	Hole diameter in mm for the sampling hole number from detector housing:				
	1	2	3	4	5
1	5.0				
2	4.0	5.0			
3	4.0	4.0	5.0		
4	3.0	3.0	3.5	5.0	
5	3.0	3.0	3.0	3.5	5.0

H-shaped sampling pipes		
Number of sampling holes per sampling branch	Hole diameter in mm for the sampling hole number ab Melderkasten:	
	1	2
1	5.0	
2	4.0	5.0



Notice

If the "ASD PipeFlow" calculation software is used, the sampling hole diameters in the table above (section 3.7) **must** be used in "ASD PipeFlow". When calculating the project, **only** the "Calculate" function may be used in "ASD PipeFlow" (not "Optimize").

3.7.1 Sampling point with heating

The sampling holes in the sampling pipe are to be implemented with heating (HEET xx PVC / HEET xx ABS) using the sampling points especially designed for refrigerated warehouses. For this purpose sets are available with different hole diameters as specified in the tables in section 3.7. Each set has its own colour code and consists of:

- T-piece with sampling hole and threaded plug in the T-exit (colour coded as shown in the following table)
- Prefabricated heating resistor
- 2 press-fit cable lugs
- 2 M3 x 14 screws
- 6 M3 hexagon nuts

Brief description	Colour code	Hole diameter in mm	
		without heating as per section 3.7	adjusted for heating
HEAT 3.0 PVC / HEAT 3.0 ABS	red	3,0	5.7
HEAT 3.5 PVC / HEAT 3.5 ABS	blue	3,5	6.1
HEAT 4.0 PVC / HEAT 4.0 ABS	green	4.0	6.3
HEAT 4.5 PVC / HEAT 4.5 ABS	black	4.5	6.7
HEAT 5.0 PVC / HEAT 5.0 ABS	brown	5.0	7.1

3.8 Electrical installation

As a rule, the power supply for the heating elements is the same as for the ASD 535 supply from the fire alarm control panel (FACP). However, this is possible only when the ASD 535 is operated with 24 VDC, since otherwise the heating elements would not be able to provide the necessary heating performance.

If an auxiliary power supply is used for the heating elements (e.g. for 12 VDC operation of the ASD 535), it is placed outside the refrigerated area (heat emission, permitted temperature of the power supply).

The heating elements should be provided with emergency power if possible.

3.8.1 Determination of the conductor cross-section

Danger

Determination of the conductor cross-section must always be carried out and protocolled. Conductor cross-sections which are too weak can result in malfunctions of the aspirating smoke detector.

Notice

For a precise determination of the maximum cable length and required cable cross-section, the power requirement of **all** heating elements for each ASD 535 (sampling pipes I and II) must be included in the calculation of the overall power requirement.

Notice

When determining the required conductor cross-section, in addition to taking the ASD 535 power consumption into account, it is necessary to take into account the limit data of the used lines and FACP technology.

The terminals of the ASD 535 are designed for a maximum of 2.5 mm². To conduct the power supply line to the heating elements or to a neighbouring ASD, it may thus be necessary to install additional distributor or support terminals.

The power requirement of consumers operated on the open collector outputs must be taken into account in the power calculation.

3.8.2 Power calculation

For maximum power consumption of an ASD 535 with heating elements, besides the ASD type (-1, -2, -3, -4) the number of present sampling points is also decisive. To simplify the calculation, the value of the ASD 535-4 can be used (system with the highest power consumption including one RIM 35).

Because the heating elements per system and sampling pipe are switched on only when needed, the power supply calculation does have to include full power consumption for all present heating elements. However, the full power consumption for the first 30 heating elements of a system (per FACP) must always be included in the calculation. This ensures that sufficient power is always available for at least three complete sampling pipes. Reduced power requirement can be reckoned for the other heating elements (see also the Notice below).

The following values are for calculating a system operating with 24 VDC:

- ASD power consumption without heating elements (24 VDC operation): Approx. 500 mA
- Power consumption for heating the first 30 heating elements: Approx. 110 mA
- Power consumption for heating the other heating elements: Approx. 65 mA

Example 1; 1 ASD 535-3, 1 ASD 535-4 with a total of 28 heating elements:

• 2 ASDs each 500 mA:	2 x 500 mA	=	1,000 mA	
• 28 heating elements each 110 mA:	28 x 110 mA	=	3,080 mA	
• 0 heating elements each 65 mA:	0 x 65 mA	=	0 mA	
	Total	=	<u>4,080 mA</u>	= <u>4.1 A</u>

Example 2; 4 ASD 535-1 with a total of 36 heating elements:

• 4 ASDs each 500 mA:	4 x 500 mA	=	2,000 mA	
• 30 heating elements each 110 mA:	30 x 110 mA	=	3,300 mA	
• 6 heating elements each 65 mA:	6 x 65 mA	=	390 mA	
	Total	=	<u>5,690 mA</u>	= <u>5.7 A</u>

Example 3; 2 ASD 535-3, 8 ASD 535-4 with a total of 148 heating elements:

• 10 ASDs each 500 mA:	10 x 500 mA	=	5,000 mA	
• 30 heating elements each 110 mA:	30 x 110 mA	=	3,300 mA	
• 118 heating elements each 65 mA:	118 x 65 mA	=	7,670 mA	
	Total	=	<u>15,970 mA</u>	= <u>16.0 A</u>

Example 4; 10 ASD 535-3, 4 ASD 535-4 with a total of 180 heating elements:

• 14 ASDs each 500 mA:	14 x 500 mA	=	7,000 mA	
• 30 heating elements each 110 mA:	30 x 110 mA	=	3,300 mA	
• 150 heating elements each 65 mA:	150 x 65 mA	=	9,750 mA	
	Total	=	<u>20,050 mA</u>	= <u>20.1 A</u>



Notice

- When operating an ASD 535 with 12 VDC, the calculation for the ASDs and the heating elements must be performed separately. In doing so, for each ASD calculate a power consumption of 835 mA (including RIM). Proceed according to the specifications above when calculating the heating elements.
- When heating element actuation is continuous, the full power consumption of 110 mA is to be expected for all heating elements (see also section 5.3; only after consulting with the manufacturer).
- When calculating the emergency power supply, the national and state-specific regulations and guidelines must be observed.

4 Mounting and installation

4.1 General information



Notice

Material and products: when setting up the system only the materials listed and approved by the manufacturer may be used (see also **section 5.1 and section 5.3** in **T 193 192**, and **T 131 194**).

The design of refrigerated facilities varies from case to case. It is therefore necessary to clarify the type of fastening for sampling pipes and detector housings with the refrigeration manufacturer (there is a risk of damaging the insulation materials of walls and ceiling).

If possible, mounting and installation should take place when the refrigerated warehouse is being built, i.e. when the ambient temperature is normal.

Mounting and installation is not permitted at temperatures of minus 30°C and less for the following reason:

- According to the manufacturer's specifications, the adhesive cannot be used under + 5°C (the hardening time of the adhesive is increased fourfold).

If installation at minus 30°C is unavoidable, the sampling pipe must be glued together in long partial sections outside the refrigerated area. The individual sections can then be connected in the refrigerated area with special threaded unions (SJ 25).

4.2 Material for the sampling pipe

The tube material is 20 mm (outer 25 mm) PVC or ABS synthetic material. The individual plastic tube parts are usually glued. By using special screw unions (SJ 25) the tube parts can also be connected without glue.

The following materials are available:

Material	Connection method
PVC (polyvinyl chloride, contains halogen)	Gluing
ABS (acrylonitrile-butadiene styrene, contains halogen)	Gluing



Notice

The two materials that can use glues (PVC and ABS) must not be combined, since different adhesives are used.



Danger

The PVC materials produce corrosive and toxic gases if they are burned or improperly disposed of. The use of PVC materials should therefore be limited to where it is expressly permitted by the operator of the facility. In applications where halogen-free plastics are stipulated, ABS materials must be used for laying the sampling pipe. Country-specific guidelines and regulations must be observed.

The **adhesives and cleaning agents** used for connecting PVC and ABS materials contain solvents and are combustible. For this reason, prior to working with these materials it is imperative to read and observe the **safety instructions and information provided by the adhesive supplier**.

A list of the available **materials for the sampling pipe** (tubes, fittings etc.) for the ASD 535 is available in a separate document (**T 131 194**).

4.3 Mounting the detector housing



Warning

- Mounting work on the detector housing is best done without fitted smoke sensors.
- The smoke sensors are always installed in the detector housing just prior to commissioning the ASD 535.
- Depending on the situation (e.g. if there is a long time between mounting and commissioning or if for example the environment is very dusty due to construction), the housing cover should be kept closed until commissioning the device.

The detector housing is to be installed in the room to be monitored, i.e. in the refrigerated area. Positioning the detector box outside the refrigerated area is permitted only after consulting with the manufacturer.

An easily accessible location should be chosen for the detector housing so that it can be worked on without aids (e.g. ladders and scaffolding). The ideal installation height of the detector housing is about 1.6 m above the ground (top edge of the detector housing).

4.3.1 Opening and closing the detector housing



Warning about opening and closing

- To open the detector box, use a **flat-blade screwdriver no. 5** (8 mm). Smaller flat-blade screwdrivers may damage the material of the rotary snap locks.
- To use the rotary snap locks, press firmly with the screwdriver toward the housing base and then turn 90°. The position of the lock slit shows the current state (see **Fig. 3**):
 - ⇒ approx. 45° angled toward detector housing corner = closed
 - ⇒ approx. 45° angled toward detector housing edge = open
 The rotary snap locks must snap into place in each case.
- The housing cover (control unit) is connected to the **Main Board** by a flat cable. Make sure that when the housing cover is lifted away the flat cable does not become damaged.

Opening / closing

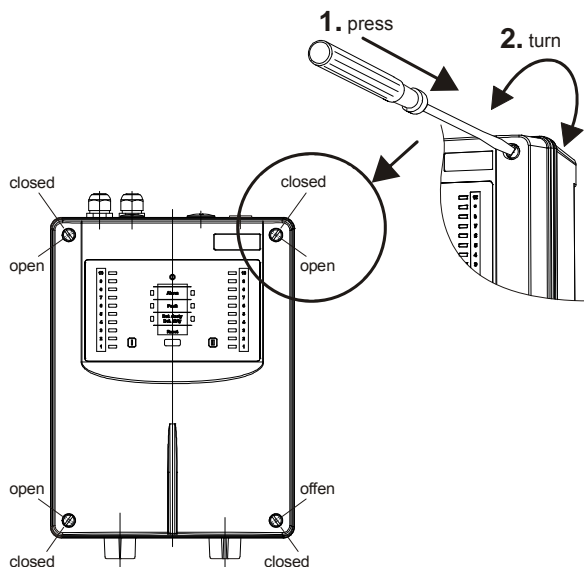

Locking

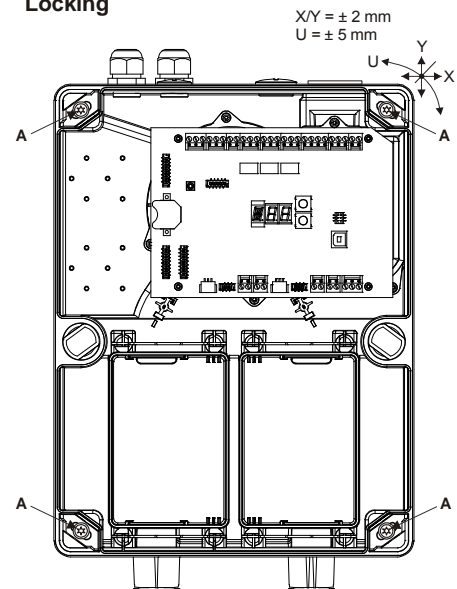

Fig. 3 Opening, closing and locking the detector housing

Mounting and installation

4.3.2 Mounting positions of the detector housing

In principle the detector housing can be mounted in the X, Y or Z axis. Because of the indicator elements labelling, however, it is advisable to mount in the Y axis (vertical, control panel up). The sampling pipes are then inserted into the detector housing from below. This makes it easier to conduct pipes to accessory parts such as duster filter units, which, for physical reasons, should always be below the ASD detector housing. If introducing the sampling pipes into the detector housing from above is unavoidable, the detector housing can be turned 180° and mounted (control panel down). So that the control panel labelling is not upside down, the labelling strips of the control panel can be changed accordingly (see also T 131 192, section 5.4.4).

For the electrical wiring of the heating elements, the **WCU 535** wiring connection unit is mounted in the sampling pipe immediately after the detector housing. When a small FBS 25 PC filter-box is used, it is positioned between the detector housing and WCU 535.

4.4 Mounting sampling pipe



Notice

The general information in technical description **T 131 192, section 5.5.6** must be observed when mounting the sampling pipe and working on the individual tube pieces.

Two different coloured 0.5 mm² silicon Litz wires (**SLW 0.5 bk** and **SLW 0.5 wt**) have to be fed into the sampling pipe for heating element control (sampling points with heating).

The individual heating elements in the sampling points are wired parallel as shown in **Fig. 4**.

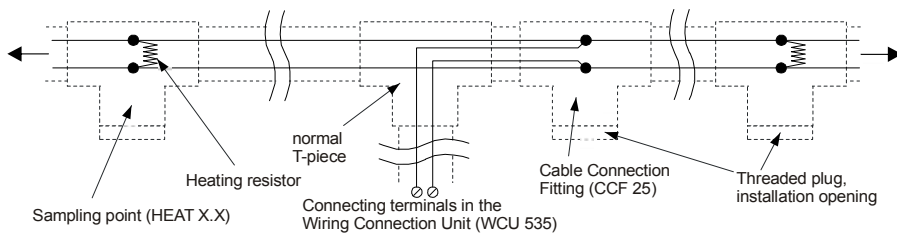

Fig. 4 Heating element wiring

So that only two silicon Litz wires have to be fed in from the ASD 535 for U-, T- and H-shaped sampling pipes, a **CCF 25** cable connection fitting must be installed directly next to the branching point (T piece). There the three wire pairs are gathered together, **Fig. 5**.

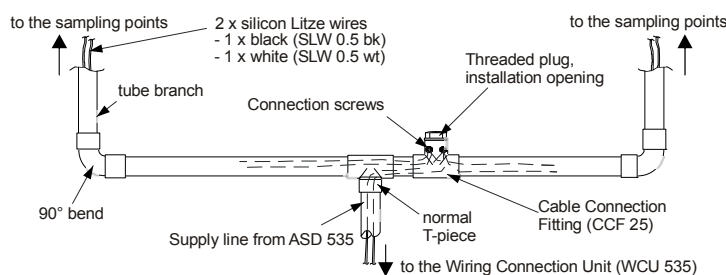

Fig. 5 Pipe layout with cable connection fitting

For the sampling points with heating and the cable connection fittings, the lateral threaded plug has to be removed and the fed in silicon Litz wires are pulled into the open at each installation opening. In doing so, a sufficient loop has to be formed (about 30 cm) so that afterwards the electrical connection can be done in accordance with section 4.4.1.

On the defined points according to section 3.7 a sampling point with heating **HEAT X.X** is installed with the correct hole diameter (colour code) in accordance with section 3.7.1.

4.4.1 Electrical connection of the silicon Litz wires

Proceed as follows to connect the silicon Litz wires to the cable connection fittings and the sampling points:

- Shorten the wire loops which are in the open through the installation openings to about 5 cm. Strip about 8 mm of insulation from the wire ends. The same colour silicon Litz wires are then twisted together and fitted with a previously assembled press-fit cable lug with screws, **Fig. 6**.
- Both pairs of wires are pushed back through the installation opening into the sampling point. The screws of the press-fit cable lug are introduced from inside through the existing fastening holes in the sampling point and fastened from outside with an M3 hexagon nut, **Fig. 7**.



Warning

The press-fit cable lugs are to be adjusted so that they do not mutually short-circuit. The sampling hole must not be covered by the silicon Litz wires that have been pushed back in.

- When connecting a cable connection fitting, proceed as described above according to **Fig. 6** and **Fig. 7**.

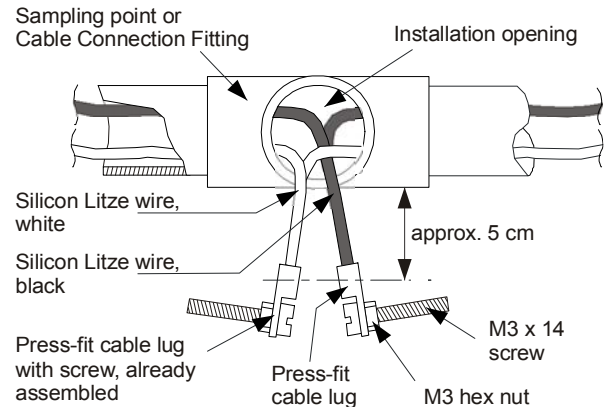

Fig. 6 Connecting the silicon Litz wires

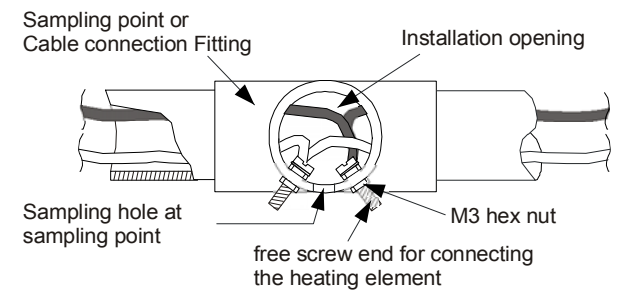

Fig. 7 Fastening the connection points

4.4.2 Mounting the heating elements on the sampling points

Proceed as follows to mount the heating resistors on the sampling points:

- Put the prefabricated heating resistor on the screw ends projecting outside and fasten with two M3 hexagon nuts, **Fig. 8**.
- The heating resistor must be precisely centred in the sampling hole, **Fig. 9**.
- After completing the connection work, screw on the threaded plug. In doing so, make sure that the plug is tight to prevent wrong air from being sampled.

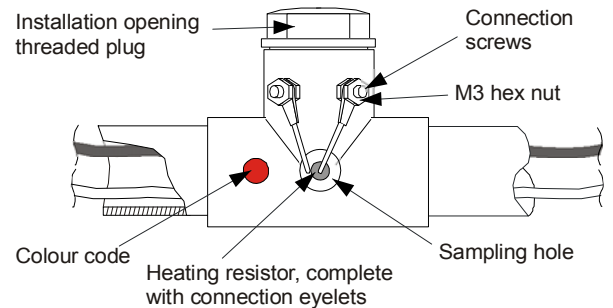

Fig. 8 Mounting the heating resistors

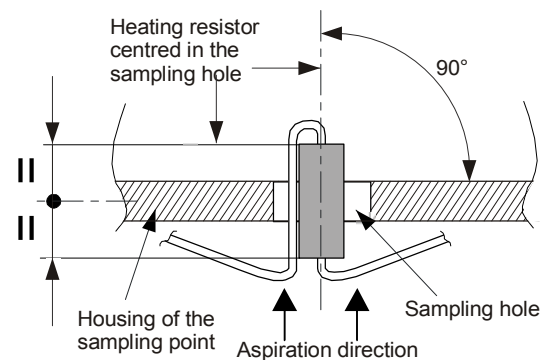

Fig. 9 Centring the heating resistor

Mounting and installation

4.4.3 Mounting and installing the WCU 535 wiring connection unit

The WCU 535 wiring connection unit is installed in the sampling pipe immediately after the detector housing (see the Notice below for an exception). A WCU 535 is required for each sampling pipe.



Notice

If a small FBS 25 PC filter-box is used, it must always be positioned between the detector housing and WCU 535.

The electrical installation of the heating control is performed from the relay in the ASD 535 and is conducted by means of a round cable via cable screw union to the WCU 535 wiring connection unit.

For an ASD 535 with two sampling pipes (ASD 535-2 / ASD 535-4) the electrical installation is conducted via a mutual cable to the WCU 535 of sampling pipe I and from there to the WCU 535 of sampling pipe II. In the WCU 535 of sampling pipe I in the cable screw union, the seal pin must be removed from the double rubber grommet.

A round cable with an outer diameter of \varnothing 5–6 mm is used for the connection cable between ASD and WCU or between WCUs (limited clamping area of the double rubber grommet).

From the WCU 535 the electrical installation is conducted via the two inside silicon Litz wires through the sampling pipe to the individual sampling points (see **Fig. 10**).

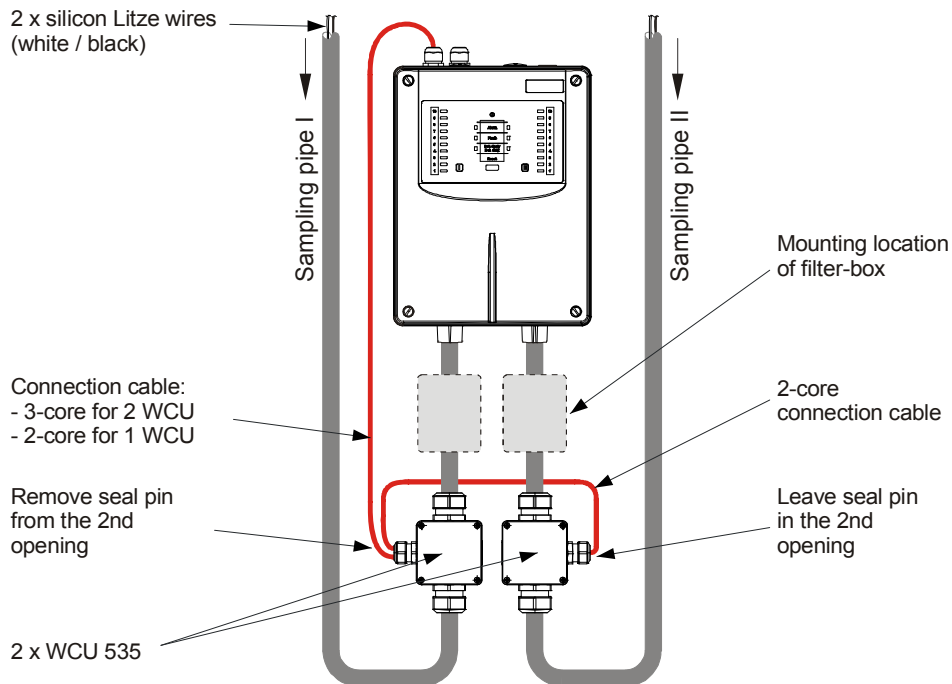

Fig. 10 Mounting and cable routing of the WCU 535



Warning

After the installation work, **firmly tighten** the cable screw unions on the WCU 535 (this prevents wrong air from entering).

4.4.4 Electrical connection in the WCU 535 wiring connection unit

The WCU 535 wiring connection unit has three 2-pin support terminals for connecting the control line from the ASD and the silicon Litz wires. These are on a retainer plate so that the airflow in the sampling pipe is able to flow unhindered through the WCU, Fig. 11.



Warning

The cables in the WCU 535 should be routed as short as possible to the support terminals. Cable loops are to be placed to the side of the retainer plate so that the airflow is not hindered.

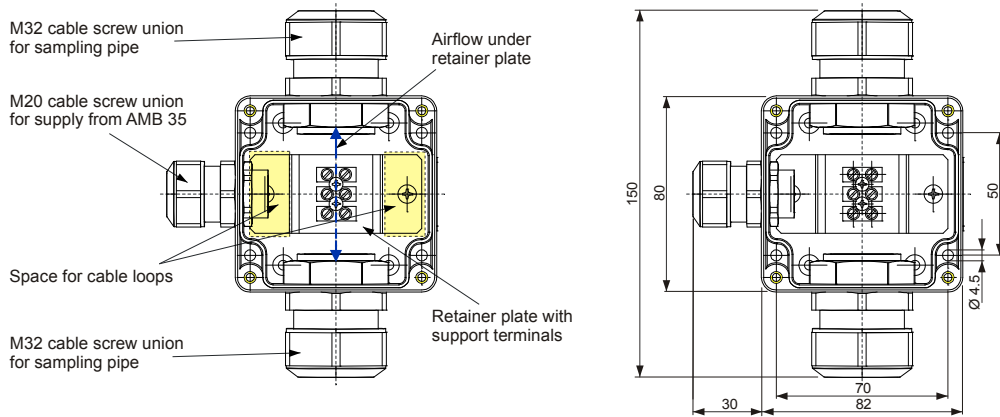

Fig. 11 Design and dimensioned drawing of the WCU 535

Fig. 12 below shows the wiring between ASD 535 and WCU 535 and their electrical connection.

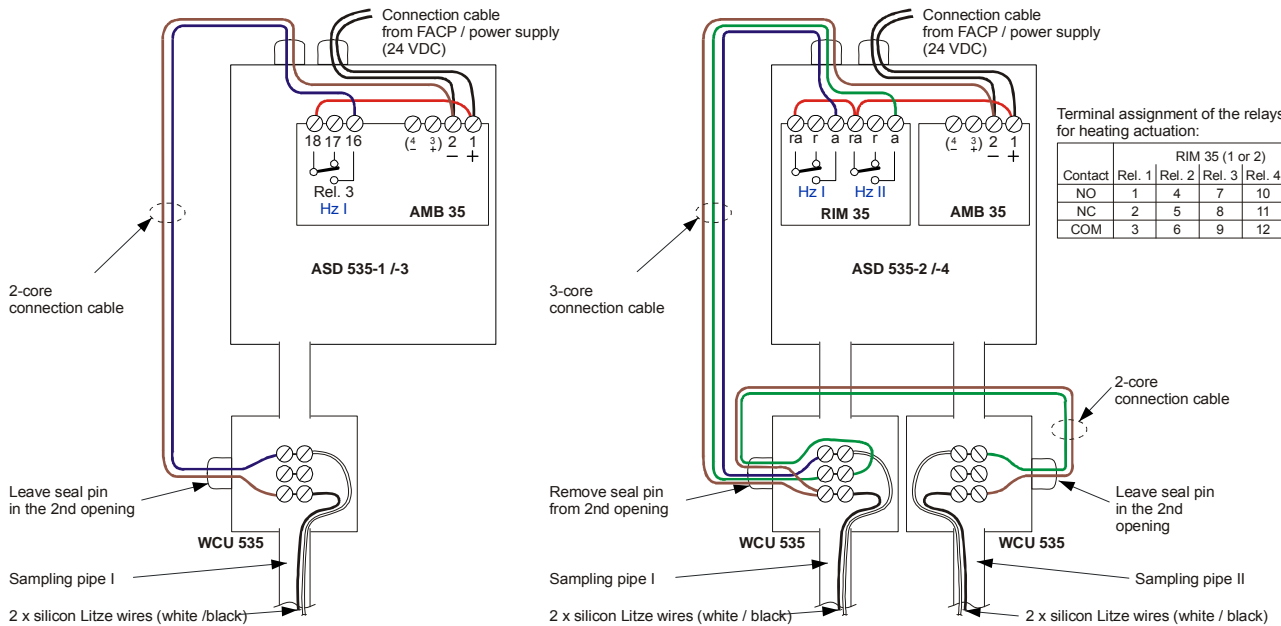

Fig. 12 Wiring between ASD 535 and WCU 535

5 Commissioning

5.1 General information



Notice

When commissioning the ASD 535 aspirating smoke detector in refrigerated warehouses, observe the information in technical description **T 193 192, section 7.1 to section 7.8.**

Prior to commissioning, it is necessary to measure the combined resistance of all connected heating resistors. The combined resistance should have the following value as a function of the number of integrated heating resistors:

Number of sampling points with heating	Resistance of the supply line measured on the support terminals in the WCU 535 (Ohm)
1	approx. 220
2	approx. 110
3	approx. 74
4	approx. 55
5	approx. 44
6	approx. 37
7	approx. 32
8	approx. 28
9	approx. 25
10	approx. 22

5.2 Initial reset



Notice

The initial reset must always be performed under the system's "normal conditions", i.e. during the normal operating temperature of the refrigerated warehouse. In addition, observe the information in technical description **T 193 192, section 7.3.5.**

5.3 Settings



Notice

ASD 535 settings are performed based on the specifications in technical description **T 193 192, section 4.8.**



Warning

If the configured LS-Ü delay time of 300 s required for the de-icing procedure in accordance with EN 54-20 (switch positions **b11** to **C32**) is not sufficient, it is possible to use switch positions **W09** to **W48** after consulting with the manufacturer. The configured values they contain concerning airflow monitoring are, however, **not** tested in accordance with EN. Continuous actuation of the heating elements is permitted only after consulting with the manufacturer.

Further, these adjustments can be implemented with the "ASD Config" configuration software in accordance with the following points:

- Increasing the LS-Ü values ($> \pm 20\%$ / > 300 s) means exceeding the normed EN 54-20 range and should be used only after consulting with the manufacturer.
- The **window size $\pm 20\%$** should in principle **not be undershot**. Smaller window sizes may be set only if, at the same time, the delay time of the airflow monitoring is increased to at least **10 min**. Due to the very high sensitivity of airflow monitoring when the window size is below $\pm 20\%$ and the delay time is ≤ 300 s, there is an increased risk of fault messages concerning airflow monitoring.

5.3.1 Programming the heating actuation

Programming the heating actuation must always be performed with the “ASD Config” configuration software. In the “Relay” tab, select the relay to use and assign the relevant event, “Heating control sampling pipe I” or “Heating control sampling pipe II”.

For the ASD 535 with only one sampling pipe (ASD 535-1 / -3) the “ASD relay 3” (AMB 35) relay can be used, Fig. 13.

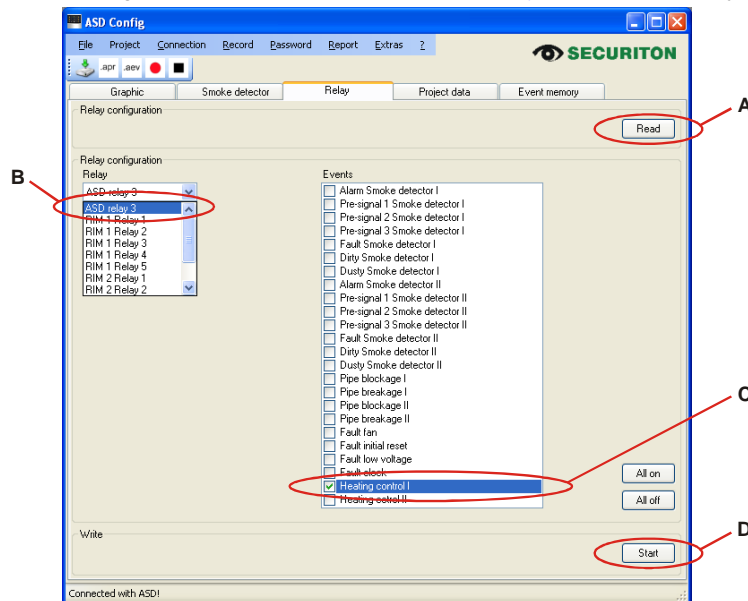

Fig. 13 Relay programming for ASD 535-1 / -3 (only one sampling pipe)

For the ASD 535 with two sampling pipes (ASD 535-2 / -4) two relays of an RIM 35 are to be used, Fig. 14.

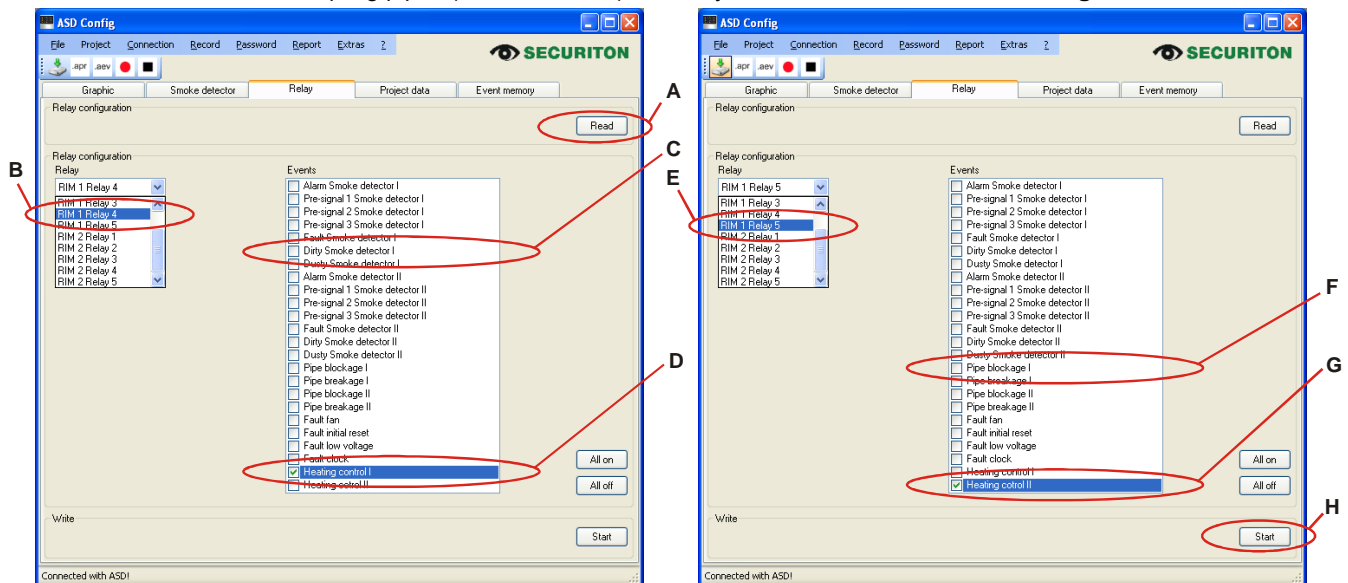

Fig. 14 Relay programming for ASD 535-2 / -4 (with two sampling pipes)

Notice

When RIM relays are used, the existing default events have to be deleted (point C and F, Fig. 14).

Commissioning

If the existing default “subsequent heating time” of 2 min is insufficient, it can be changed with the “ASD Config” configuration software via “Extras” > “General settings” in the range of 1 to 60 min, Fig. 15.

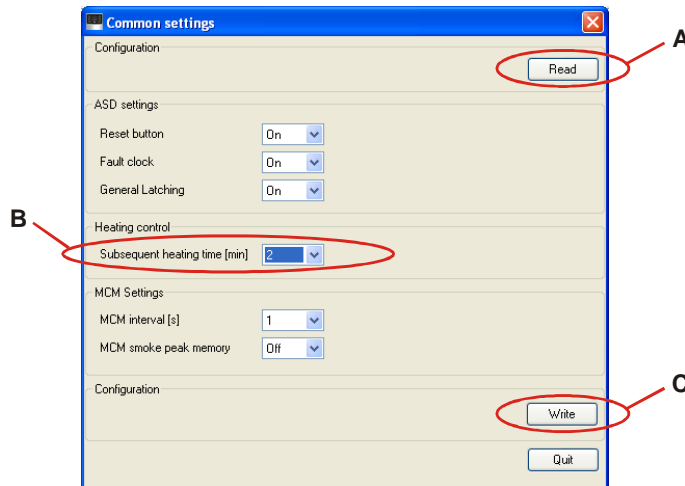

Fig. 15 Changing the subsequent heating time

5.4 Checking heating control

In the framework of checking the airflow monitoring in accordance with section 7.7 in technical description T 193 192, the functionality of the heating control is tested by taping several sampling holes. The tests are entered in the commissioning protocol.



Warning

When you tape the sampling opening, make sure not to damage the heating resistors. After the test, open the sampling holes completely. Make sure that the heating resistors are still correctly centred in the sampling holes (see also Fig. 9).

Test event	Procedure	Action / result
Replication of sampling hole icing	Tape sampling holes (adhesive tape); the required number depends on the tube configuration.	<ul style="list-style-type: none"> As soon as the resulting change in the airflow rate is exceeded (e.g. “Deviation negative” 20%), which can be checked via the switch setting V, the “Fault” LED begins to flash. The heating resistors are addressed
Checking heating voltage	Measure the heating voltage on the two terminal screws (heating resistance) of a taped sampling hole using a multimeter.	<ul style="list-style-type: none"> Voltage value 19–24 VDC.
Checking the power consumption of the heating resistors	Undo the installation wire in the ASD 535 on the switched terminal of the heating relay (AMB Class 16 for ASD 535-1/-3 or contact “NO” on RIM). Measure the current between the terminal and the free installation wire. Afterward, re-connect the installation wire.	<ul style="list-style-type: none"> 1 heater approx. 109 mA 2 heaters approx. 218 mA 3 heaters approx. 327 mA 4 heaters approx. 436 mA 5 heaters approx. 545 mA 6 heaters approx. 654 mA 7 heaters approx. 763 mA 8 heaters approx. 872 mA 9 heaters approx. 981 mA 10 heaters approx. 1,090 mA <p>The current values are based on an ASD power supply of 24 VDC (Class 1/2). For each Volt difference the power consumption of the heating resistors increases or decreases by approx. 4.5 mA.</p>
Replication of the de-icing procedure	Completely open the sampling holes while the LS-Ü delay time is in effect (default 300 s).	<ul style="list-style-type: none"> The airflow rate increases again; as soon as the “Deviation negative” is exceeded, the “Fault” LED goes out.
Checking the subsequent heating time	Measure the heating voltage on the two terminal screws (heating resistance) of a sampling hole using a multimeter.	<ul style="list-style-type: none"> Beginning when the “Fault” LED goes out, the heating voltage must continue to be present for the duration of the configured subsequent heating time (e.g. default 2 min).

6 Article numbers and replacement parts

6.1 Detector housings and accessories

Designation	Article no.
Aspirating Smoke Detector ASD 535-1 without smoke level indicator, for 1 smoke sensor (no smoke sensor)	5000623.0101
Aspirating Smoke Detector ASD 535-2 without smoke level indicator, for 2 smoke sensors (no smoke sensor)	5000623.0102
Aspirating Smoke Detector ASD 535-3 with smoke level indicator, for 1 smoke sensor (no smoke sensor)	5000623.0103
Aspirating Smoke Detector ASD 535-4 with smoke level indicator, for 2 smoke sensors (no smoke sensor)	5000623.0104
Smoke sensor SSD 535-1, 0.5%/m to 10%/m	5000613.0101
Smoke sensor SSD 535-2, 0.1%/m to 10%/m	5000613.0102
Smoke sensor SSD 535-3, 0.02%/m to 10%/m	5000613.0103
SecuriLine® module SLM 35 including mounting set	4000286.0101
Relay Interface Module RIM 35 including mounting set	4000287.0101
Memory Card Module MCM 35 with SD memory card (min. 1 GB) incl. mounting set	4000285.0101
SD memory card (min. 1 GB)	4000314.0102
USB cable, 4.5 m	4301248
CD with "ASD Config" configuration software	4800106
CD with "ASD PipeFlow" calculation software	4800107
Printed circuit board Main Board AMB 35-1 (for ASD 535-1 / -3)	94301218.0101
Printed circuit board Main Board AMB 35-2 (for ASD 535-2 / -4)	94301218.0102
Printed circuit board without smoke level indicator BCB 35	4301220.0101
Printed circuit board with smoke level indicator ACB 35	4301221.0101
Aspirating Fan Unit AFU 35, complete	4000299
Air Flow Sensor AFS 35	4000300
Lithium battery	2310032
Cable screw union M20	3610354
Cable screw union M25	3610424
Universal module support UMS 35	4301252.0101

6.2 Sampling pipe and accessories

The article numbers of all available parts of the sampling pipe (tubes, fittings, etc.) as well as the components for use in refrigerated warehouses are listed in a separate document (T 131 194).

7 Technical data for use in refrigerated warehouses

Type				ASD 535	
Supply voltage range				10.5 to 30	VDC
Max. power consumption, measured in Fan speed level V and at →	12 VDC operation	24 VDC operation	Typical		
	10.5 VDC ①	18 VDC ①	24 VDC		
ASD 535-1	Idle/fault	approx. 575	approx. 340	approx. 260	mA
	Alarm I	approx. 660	approx. 390	approx. 295	mA
ASD 535-2	Idle/fault	approx. 645	approx. 380	approx. 290	mA
	Alarm I + II	approx. 745	approx. 450	approx. 350	mA
ASD 535-3	Idle/fault	approx. 575	approx. 340	approx. 260	mA
	Alarm I	approx. 695	approx. 405	approx. 310	mA
ASD 535-4	Idle/fault	approx. 645	approx. 380	approx. 290	mA
	Alarm I + II	approx. 820	approx. 490	approx. 385	mA
Additionally with 1 RIM 35 unit	approx. 15	approx. 10	approx. 7		
Additionally with 2 RIM 35 units	approx. 30	approx. 20	approx. 14		
Additionally with SLM 35	approx. 20	approx. 10	approx. 5		
Additionally with MCM 35	approx. 25	approx. 15	approx. 10		
Power consumption per sampling point with heating ① (at 24 VDC)				110	mA
Switch-on current peak ② (caused by EMC protection elements on the ASD supply input)				approx. 5	A
				for max. 1	ms
Sampling pipe length				See section 3.5	
Sampling pipe Ø, typical (inner/outer)				Ø 20 / 25	Mm
Max. number of sampling holes				See section 3.5	
Sampling hole diameter				Ø 3 / 3.5 / 4 / 4.5 / 5	mm
Response range				EN 54-20, Class A, B, C	
Protection type acc. to IEC 529 / EN 60529 (1991)				54	IP
Ambient conditions acc. to IEC 721-3-3 / EN 60721-3-3 (1995)				3K5 / 3Z1	Class
Extended ambient conditions:					
• Detector housing temperature range				-30 – 0 ③	°C
• Sampling pipe temperature range				-30 – 0 ③	°C
• Max. approved temperature fluctuation in detector housing and sampling pipe operation				20 ③	°C
• Max. permitted storage temperature of detector housing (without condensation)				-30 – +70	°C
• Ambient pressure difference of detector housing to sampling pipe (sampling holes)				Must be identical	
• Detector housing humidity ambient condition (transient without condensation)				95	% rel. hum.
• Humidity ambient humidity (continuous)				70	% rel. hum.
Max. loading capacity relay contact				50	VDC
				1	A
				30	W
Max. loading capacity per open collector output (electrical strength 30 VDC)				100	mA
Plug-in terminals				2.5	mm ²
Cable entry for cable Ø				Ø 5 – 12 (M20) / Ø 9 – 18 (M25)	
Noise level (at fan speed level III)				43	dB (A)
Map case (housing) material				ABS blend, UL 94-V0	
Map case (housing) colour				Grey 280 70 05 / anthracite violet 300 20 05	
Approval				EN 54-20	
Dimensions (W x H x D)				265 x 397 x 146	
Weight (ASD 535-4, incl. expansion modules)				max. 3850	g

Notice



- ① Power consumption at maximum permitted voltage drop in the electrical installation (guideline value for calculating the conductor cross-section).
- ② May cause an immediate actuation of the protection circuit in power supplies with overload protection circuits (primarily in devices with no emergency power supply and output current of < 1.5 A).
- ③ The specified temperature range applies only to use in refrigerated warehouses. The manufacturer must be consulted if deployment is to be in the condensation range.

8 List of figures

Fig. 1 Sampling pipe definitions	13
Fig. 2 Size of the sampling holes	16
Fig. 3 Opening, closing and locking the detector housing	21
Fig. 4 Heating element wiring	22
Fig. 5 Pipe layout with cable connection fitting	22
Fig. 6 Connecting the silicon Litze wires	23
Fig. 7 Fastening the connection points	23
Fig. 8 Mounting the heating resistors	23
Fig. 9 Centring the heating resistor	23
Fig. 10 Mounting and cable routing of the WCU 535	24
Fig. 11 Design and dimensioned drawing of the WCU 535	25
Fig. 12 Wiring between ASD 535 and WCU 535	25
Fig. 13 Relay programming for ASD 535-1 / -3 (only one sampling pipe)	27
Fig. 14 Relay programming for ASD 535-2 / -4 (with two sampling pipes)	27
Fig. 15 Changing the subsequent heating time	28