



The Securiras ASD 533 (Aspirating Smoke Detector) is the new generation of a highly sensitive, active smoke detection system. It is based on the successful ASD 535 and is particularly well suited for smaller monitoring areas and sampling distances where a reduced sampling performance is sufficient.

Securiras ASD 533

Aspirating Smoke Detector

Design and function

The Securiras ASD 533 consists of a fan, a highly sensitive smoke sensor, an airflow measurement system, and evaluation electronics. The fan sucks in air samples through the sampling holes from the room or facility being monitored and then feeds the samples through a sampling pipe to the evaluating processor unit. Here the air samples are continually monitored for smoke particles by the smoke sensor.

Airflow monitoring ensures that the sampling pipe is constantly checked for pipe breakage and any soiling of the sampling holes.

The display and control panel of the evaluating processor unit indicates alarm, fault and status reports. Any increase in smoke concentration levels is detected very early. Three presignals and two main alarms can be programmed and forwarded to a fire alarm control panel either via potential free relays or directly to the Securiline addressable loop.

Applications

The Securiras ASD 533 is used whenever conventional point-type smoke detectors cannot be used. This may be due for example to ambient conditions (too hot, too cold, too dirty) or because operating conditions are such that access is highly restricted (prisons, false ceilings, clean rooms, laboratories, high-rack storage facilities, etc.). Or because lightning-fast detection is required, e.g. in data centres.

Typical applications include:

- Space surveillance
 - Elevator shaft monitoring
 - Museums, galleries, theatres, and cinemas
- Collections of cultural artefacts, historical buildings
- IT and data centres
- Telecommunication centres
- Laboratory and research centres
- Transformer rooms
- Clean rooms

- Property surveillance
 - Telecommunication facilities
 - High- and low-voltage distribution cabinets
 - Display cases
 - EDP facilities
 - CNC control systems
- Invisible application
 - Prison cells
 - Protection of cultural assets

Highly sensitive smoke sensor

The SSD 533 smoke sensor was specially developed for the Securiras ASD 533 and is based on the well-known SSD 535. A high-power LED combined with an LVSC (Large Volume Smoke Chamber) sampling chamber results in unparalleled adjustable sensitivity with low aerodynamic resistance and the utmost resistance to soiling and contamination. These features ensure long system service life and durability.

Easy to plan and commission

For standard installations the Securiras ASD 533 allows fast and foolproof commissioning without a PC using EasyConfig. More complex installations are calculated using the ASD PipeFlow software and configured using ASD Config, the PC commissioning and maintenance software. This makes it possible to configure more cost-efficient asymmetrical pipe layouts. The optional MCM 35 memory card module allows extensive long-term smoke level recordings (e.g. smoke and airflow values) to be stored directly on the SD memory card and analysed on your PC.

Accessories and options

With the exception of the flame arrester and the accessory parts for deep-freeze applications the Securiras ASD 533 is compatible with all the usual ASD 535 sampling tubes with $D = 25$ mm and other accessories. All of these can also be calculated using ASD PipeFlow.

- Latest generation of aspirating smoke detectors for simple applications
- 1 sampling pipe/1 detector
- EN 54-20 classes A, B, and C
- 5 alarm levels (3 prealarms and 2 alarms)
- Response sensitivity settable from 0.02–10%/m
- Insensitive to dirt particles thanks to particle suppression
- Autolearning function
- Low noise level, compliant with ISO 11690-1
- Perfected smoke detection thanks to HD sensor (high-dynamic technology)
- Low power consumption
- Easy to commission without PC tool
- ASD Config PC tool
- ASD PipeFlow calculation tool

The device concept is compatible with the use of the following options:

- Relay interface module RIM 35
- Memory card module MCM 35
- Securiline module SLM 35 and XLM 35
- The SSD 533-3 smoke sensor is fitted ex works
- No provision is made for networking with SIM 35 (RS 485)

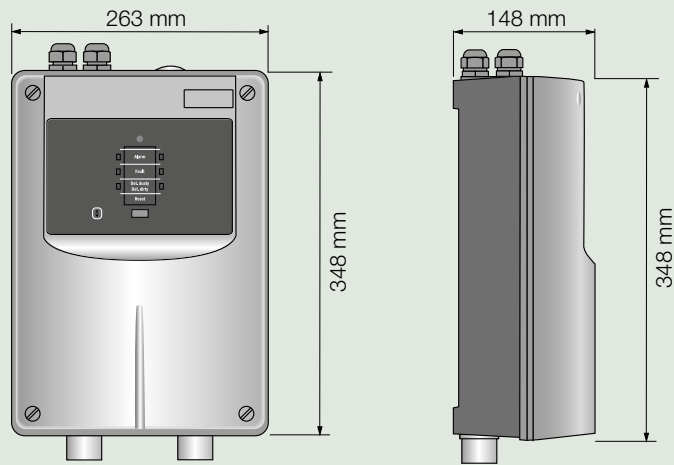

Specifications subject to change without notice. Delivery subject to availability.

Technical data

| | |
|--|--|
| 10.5–30 V DC | Permitted voltage range |
| 130 mA typ. (at 24 V DC) | Operating current, quiescent (typical) |
| 0.02–10%/m (0.00087–0.457 dB/m) | Alarm sensitivity |
| 0.002–9%/m | Presignals 1, 2 and 3, programmable in 10% increments |
| 3 relays/open collector | Interfaces (alarm, fault, programmable) |
| USB | Service interface |
| 4 (SLM 35, MCM 35, XLM 35 and 2x RIM 35) | Number of expansion slots |
| 30 V DC/1 A | Relay contact load |
| EN 54-20, classes A, B and C | Standards |
| Approvals | VdS G registered, 0786 CPD registered |
| –20 °C at +60 °C | Ambient operating temperature |
| IEC 529 protection type | IP 54 (achieved without limitations) |
| 348 × 263 × 146 mm | Map case dimensions (l × w × h) |
| RAL 280 70 05 light grey | Map case colour |
| RAL 300 20 05 anthracite | |
| ABS blend, UL 94-V0 | Map case material |
| Approx. 3,200 g | Weight |
| 1 LED (green): POWER | Standard display and control |
| 2 LEDs (yellow): Fault/Soiling | |
| 1 LED (red): Alarm | |
| 1 reset button | |
| Up to max. 430 events | Event data memory (without MCM 35) |
| Up to max. 1 year | Analogue-value logging (with MCM 35) |
| 4 × M20, 1 × M25 | Cable entries |
| Fan | Radial, speed not adjustable |
| 65,000 hours (at 40 °C) | Fan service life |
| Typ. 32 dBA | Suction noise (complies with ISO 11690-1: for the design of low-noise workplaces containing machinery) |
| Class A: 7 sampling holes/50 m | System limits according to EN 54-20 (sampling holes/furthest sampling hole) |
| Class B: 9 sampling holes/70 m | |
| Class C: 12 sampling holes/80 m | |