

# APPLICATION DATA SHEET

WWW.OLIVER-IGD.CO.UK

**OLIVER IGD**

Control Systems

Transmitters

Sensors

Accessories

## TOCSIN 102 Series Gas Detectors

- 4-20mA Device 2 and 3 Wire
- Addressable Versions
- Compact Size
- Exd Certified
- ATEX Certified
- Ingress Protection IP66
- Stainless Steel Housing

Available as:

- 2 Wire Toxic Gas Detector
- 2 Wire Oxygen Sensor
- 3 Wire 'Pellistor' Flammable Gas Detector.
- 3 Wire 'Infra Red' Flammable Gas Detector
- 3 Wire 'Infra Red' CO2 Gas Detector

The Tocsin 102 series of gas detectors are ATEX approved sensors which incorporate micro processor technology to give a stable 4-20mA process signal output. The in built processor can be used to pre-calibrate the sensor prior to installation. A range of sensing technologies can be incorporated into the housing to provide the most appropriate detection method. Available sensor types include IGD's own MKIII and Type B Pellistors, Infra red and Electrochemical devices.

## General Specification

Specification	
Power supply	18 to 32V DC
Electrical Outputs	2 and 3 Wire 4-20mA
Temperature	-10°C to +50°C (Pellistors to -30°C)
Humidity	15 to 90% RH non-condensing
Ingress Protection	IP66
Housing Material	Stainless Steel 316 S16
Protection Concept	Flameproof
Dimensions (mm)	50 Diameter x 80 Length
Mounting Thread	M20 x 1.75
Weight	550 grams

Ex d IIC T6

CE 0518

Ex II 2 D G

Sira 02ATEX1271X



International Gas Detectors

CH<sub>4</sub> H<sub>2</sub>S CO<sub>2</sub>  
NO<sub>2</sub> NO SO<sub>2</sub>



Pepper Road  
Bramhall Technology Park  
Stockport  
SK7 5BW  
England

Tel: +44 (0)161 483 1415  
Fax: +44 (0) 161 484 2345  
Email: sales@oliver-igd.co.uk  
Website: www.oliver-igd.co.uk



Ref ROS65A

# TOCSIN 102

## Toxic, Flammable & Oxygen Gas Detectors

Sensor type	Basic Part Number	Suffix 'A' For Addressable Sensor	Min Range	Max Range
Flammable Gas MK3 Sensor 4-20mA All Flammable Gases Typically:  Methane Propane n-Butane n-Pentane n-Hexane N-Heptane n-Octane Hydrogen Methanol Ethanol Iso Propyl Alcohol Acetone Methyl Ethyl Ketone Benzene Toluene Di-ethyl Ether Cyclohexane Ammonia	5108601	A		0-100%LEL
Flammable Gases Infra-Red Point  Methane Propane n-Butane n-Pentane n-Hexane	5107901	A		0-100%LEL
Carbon Dioxide Infra-Red Point	5112701	A	0-5000ppm	0-5%
Carbon Monoxide	5107101	A	0-100ppm	0-1000ppm
Nitric Oxide	5106801	A	0-10ppm	0-250ppm
Nitrogen Dioxide	5106301	A	0-10ppm	0-50ppm
Hydrogen Cyanide	5107201	A	0-5ppm	0-200ppm
Chlorine (safe area only non ATEX)	5106601	A	0-5ppm	0-50ppm
Hydrogen Sulphide	5106501	A	0-20ppm	0-250ppm
Ammonia	5107001	A	0-100ppm	0-500ppm
Oxygen	5106701	A	0-5%	0-35%
Sulphur Dioxide	5106401	A	0-5ppm	0-50ppm
Hydrogen Chloride	5106101	A	0-5ppm	0-50ppm



**IGD Manufactured Pellistors  
MKIII MKIV & Type B  
Poison Resistant  
High Reliability  
Field Proven**



**Infra Red Gas Detectors**



**Electrochemical Gas Detectors**



International Gas Detectors

CH<sub>4</sub> H<sub>2</sub>S CO<sub>2</sub>  
NO<sub>2</sub> NO SO<sub>2</sub>



Pepper Road  
Bramhall Technology Parl  
Stockport  
SK7 5BW  
England

Tel: +44 (0)161 483 1415  
Fax: +44 (0) 161 484 2345  
Email: sales@oliver-igd.co.uk  
Website: www.oliver-igd.co.uk



Ref ROS65A

# TOCSIN 102

## Infra Red Point Gas Detectors

The Tocsin 102IR series of gas detectors uses the proven Non-Dispersive (NDIR) principle to detect and monitor the presence of gases.

The detectors are supplied as pre-calibrated units with linear 4-20mA outputs. If necessary the detector head can be field calibrated or re-configured for different gases or ranges using its inbuilt serial port and separate data terminal. The infra red detectors employed have been field proven over many years use resulting in a series of detector heads with excellent stability and reliability in the most arduous conditions. The detector heads have their own control software which continually monitors the head performance. This ensures that in the unlikely event that a fault occurs it is detected and reported immediately. Using the inbuilt serial port this series of detector heads can be integrated onto addressable systems such as the Tocsin 700 or 900 control panels allowing sensors to be 'daisy' chained for ease of installation and operation.

- LONG MTBF
- EXTENDED CALIBRATION PERIODS
- ALL STAINLESS STEEL CONSTRUCTION
- ADDRESSABLE SERIAL PORT
- CAN BE FIELD CALIBRATED
- LINEAR 4-20mA OUTPUT
- AVAILABLE FOR A WIDE RANGE OF FLAMMABLE GASES AND CO2

<b>Performance</b>	
Operation	Continuous
Resolution	2%FSD
Warm up time to final zero	< 20 s
Warm up time to specification	< 30 minutes
Response time to target gas T90	< 20 s
MTBF	> 5 years
Long Term Zero Drift Per Month	+/-0.05%
Zero Repeatability During Operation	+/-0.1%
Span (5%) Repeatability During Operation	+/-0.1%
<b>Environmental:</b>	
Operating Temperature	-10 to +50 Deg C
Storage Temperature	-20 to +60 Deg C
Relative humidity (non-condensing)	0 to 100%
<b>Connections</b>	
Outputs	3 Wire 4-20mA RS232
Power Input	18 to 32V DC
Power Consumption	90mW
<b>Physical</b>	
Ingress Protection	IP66
Housing Material	Stainless Steel 316 S16
Protection Concept	Flameproof
Dimensions (mm)	50 Diameter x 80 Length
Mounting Thread	M20 x 1.75
Weight	550 grams

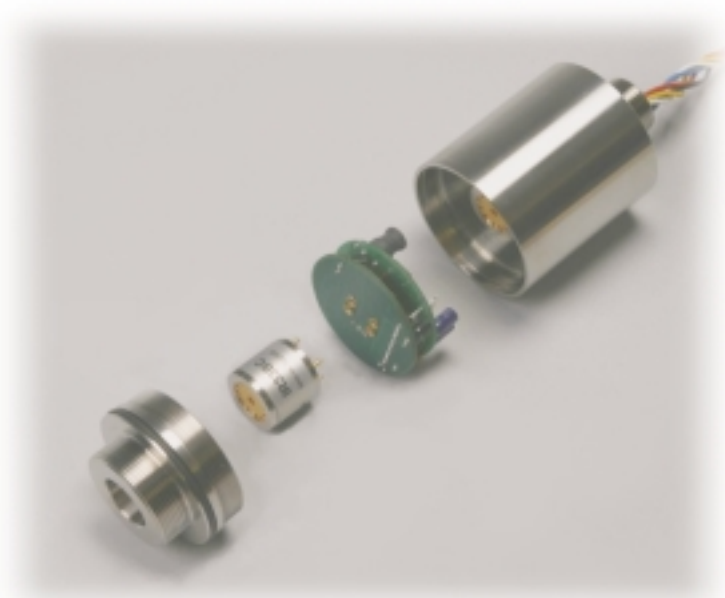

**EEx d IIC T6**

**CE** 0518

**Ex** II 2 D G

Sira 02ATEX1271X

METHANE  
 PROPANE  
 BUTANE  
 ACETYLENE  
 HEXANE  
 ETHYLENE  
 BENZENE

AIRCRAFT FUEL JP-4  
 PETROL VAPOURS



International Gas Detectors

CH<sub>4</sub> H<sub>2</sub>S CO<sub>2</sub>  
 N<sub>2</sub> SO<sub>2</sub> NO<sub>2</sub> O<sub>2</sub>



Pepper Road  
 Bramhall Technology Parl  
 Stockport  
 SK7 5BW  
 England

Tel: +44 (0)161 483 1415  
 Fax: +44 (0) 161 484 2345  
 Email: sales@oliver-igd.co.uk  
 Website: www.oliver-igd.co.uk



Ref ROS65A

# TOCSIN 102

## SENSOR OPTIONS & ACCESSORIES

### TOCSIN 102 SHOWN WITH EEXd JUNCTION BOX

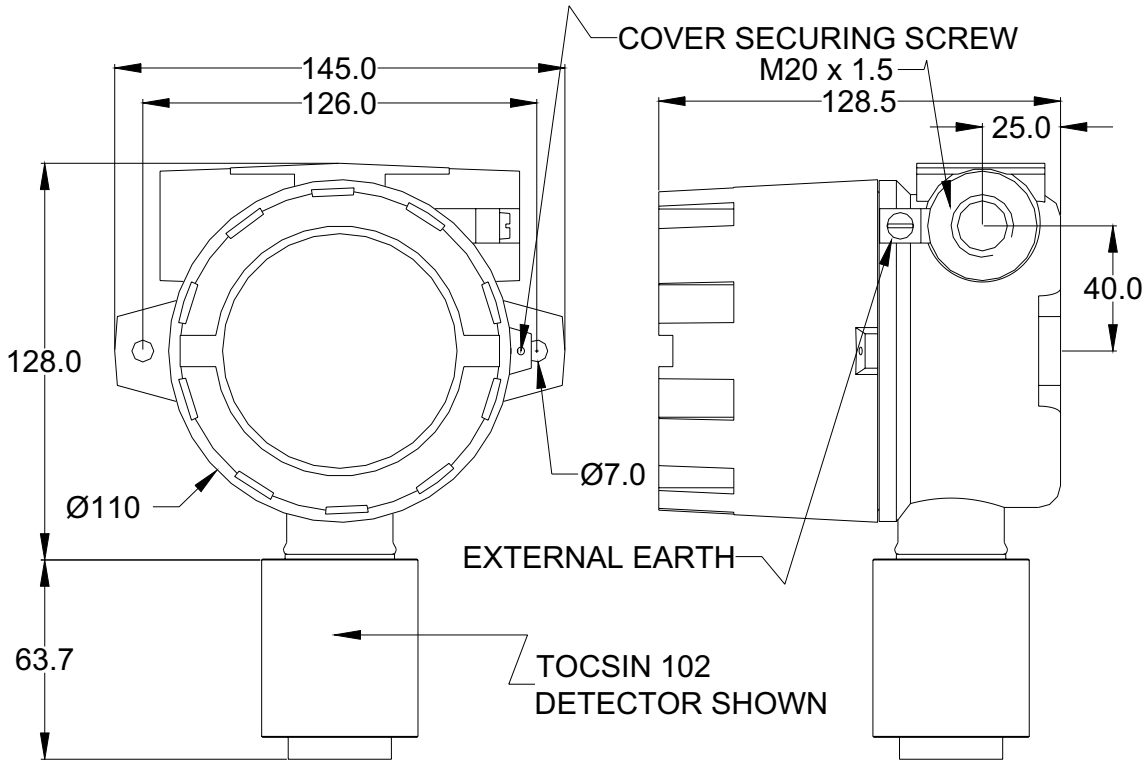

Standard Junction Box P/N 5045801  
As Above Diagram

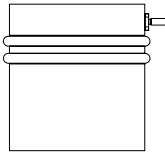

Weather Protection Assembly  
Incorporating Test Gas Applicator P/N 401451

Collector Cone P/N 401061

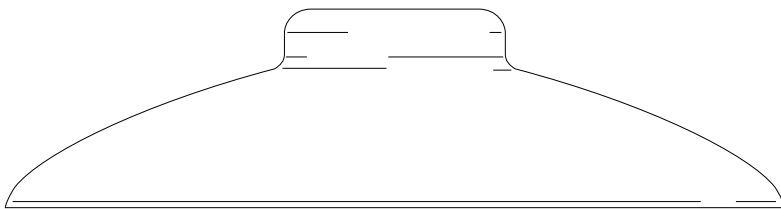

Engineers Test Gas  
Applicator For Tocsin 102 P/N 401101A

For Compatible Oliver IGD Control Panels See:

- The Tocsin 601 Single Channel controller
- The Tocsin 700 One to Sixteen Channel Controller
- The Tocsin 900 Addressable System Controller
- The Tocsin 903 EEx Single Channel Controller
- The Tocsin 800/850 19" Rack System



International Gas Detectors

CH<sub>4</sub> H<sub>2</sub>S CO<sub>2</sub>  
NO<sub>2</sub> NO SO<sub>2</sub>



Pepper Road  
Bramhall Technology Park  
Stockport  
SK7 5BW  
England

Tel: +44 (0)161 483 1415  
Fax: +44 (0) 161 484 2345  
Email: sales@oliver-igd.co.uk  
Website: www.oliver-igd.co.uk



Ref ROS65A